



**Tuesday 14 April**  
**Thursday 16 April**

**Tuesday 7 July**  
**Thursday 9 July**

# ***Summer Enrichment Programme 2026***

**Tuesdays & Thursdays : period 6 : 3-4pm**

# Instructions for Academic Tutors and Students

1. Present these instructions with your tutor group - focusing on **slides 2-13**
2. Direct students to read through the rest of the guide describing the enrichment activities on offer
3. Students must complete the Enrichment Preferences Google Form during tutor periods / at home

## **Important Things for students to be aware of when choosing your preference:**

- You must check the **gender/age restrictions** on some activities.
- Choose your preference for **THREE different activities (1st choice, 2nd choice, 3rd choice)** for **Tuesday**
- Choose your preference for **THREE different activities (1st choice, 2nd choice, 3rd choice)** for **Thursday**
- Remember these are **preferences NOT choices - nothing is guaranteed except for an invitation only Enrichment** which you would have been told about before

**If you pick an incorrect age/gender group, you will be placed in a spare enrichment**

**If you choose the same enrichment for all 3 options - you will be placed in a spare enrichment**

**YOU MUST ONLY ATTEND THE ENRICHMENT ON YOUR ARBOR**  
**Any Enrichment changes are only approved by Mr Briggs**

# KS3 Enrichment Sign up! : Summer Term 2026

Sign up is open for 1 week : TUES 16 MAR - MON 23 MARCH **period 1 deadline**

The Enrichment guide and sign up is on classroom so please take time to choose carefully

- no changes will be allowed in Summer Term
- remember you have 3 choices!

No iPad to make your choices?

Ask your tutor to complete your Enrichment google form by Monday

Once your Enrichment is locked in,  
no changes will be made

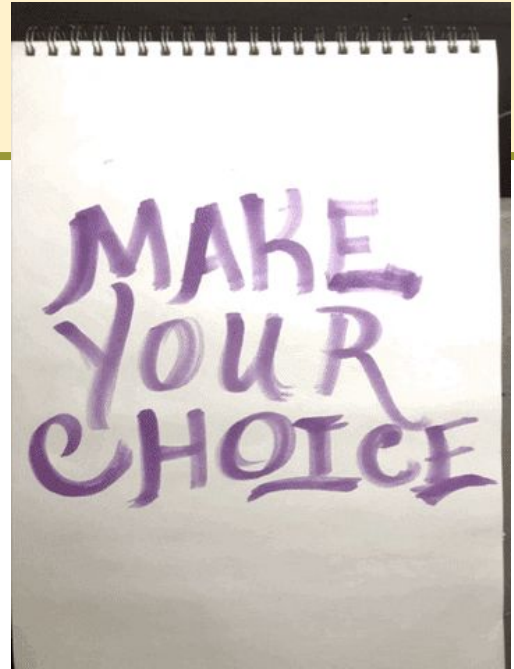

What do I do  
if I find my  
Enrichment hard  
and I don't want  
to do it anymore?

**Challenges are not obstacles, but  
opportunities for growth and change.**

Elizabeth Garrett Anderson



What is the point of doing new activities in Enrichment when I know what I like?

We need diversity of thought in the world to face the new challenges.

Tim Berners-Lee





## *Our enrichment programme*

- ★ Encourages students to be healthy and active by aiming to participate in at least one Sport & Fitness activity each week.
- ★ Empowers students with the skills and knowledge they need to make excellent choices about their next steps after school.
- ★ **PLEASE NOTE:** we will make every effort to give you your enrichment preference but this is not always possible as all sessions have a maximum number of participants and we want to build resilience and flexibility in our students

What happens if I don't know what I've got to do or where I've got to go?

Shall I just go wherever I want or should I check Arbor and the screens for information or maybe ask a teacher?

“

I am much pleased to find how very well I stand work & how my powers of attention & continued effort increase.

—  
ADA LOVELACE

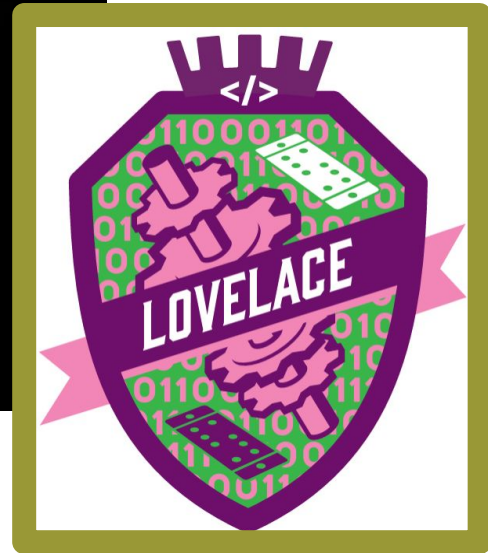

# How to use your Enrichment guide

Symbols will be used to give you information about each Enrichment activity



This is a brand new Enrichment class



This Enrichment class is appropriate for all genders



This Enrichment class is allocated to Boys



This Enrichment class is allocated to Girls



This Enrichment requires you to be in your PE kit



This Enrichment class requests a small voluntary parental contribution to help pay for resources

7

This Enrichment class is allocated to Year 7 students

8

This Enrichment class is allocated to Year 8 students

9

This Enrichment class is allocated to Year 9 students



This Enrichment is allocated to students by invitation only

There are other year groups in my Enrichment and I've changed my mind!

I learned that courage was not the absence of fear, but the triumph over it. The brave man is not he who does not feel afraid, but he who conquers that fear.

Nelson Mandela

quote:anay





# Instructions



The  
Richmond  
upon Thames  
School

Tuesday 14 April  
Thursday 16 April

-

Tuesday 07 July  
Thursday 09 July

## *Instructions for Enrichment sign-up*

- ★ I will choose **THREE** activities for Tuesdays
- ★ I will choose **THREE** activities for Thursdays
- ★ I will try to choose at least **ONE** physical enrichment
- ★ I will choose wisely based on **my own goals and interests**
- ★ I am **committing to these enrichment classes** for the entire term and will not be permitted to change mid-term
- ★ I will aim to **try a new activity** each term

I didn't get my first  
choices so I don't  
want to do my  
Enrichment

Expectation is the  
root of all heartache.

William Shakespeare

quotefancy





I am a positive member of my community  
**I believe in the power of effort**  
I am an active participator  
I am kind and happy  
I am confident  
**I am ready to learn**

 **The Richmond upon Thames School**  
Excellence Through Endeavour

## *Enrichment Expectations*

- ★ I listen, follow instructions and make an effort in every activity
- ★ I represent the ethos of the school by being kind, happy and participating fully

**I don't like this Enrichment so  
I'm not going to the classroom  
and you can't make me!**

**Without motivation there is no  
sacrifice, without sacrifice there is  
no discipline and without  
discipline there is no success.**



# Preferences

*CHOOSE THREE ENRICHMENTS*



# Tuesday



# Annyeong!



If you want to learn all about Korean culture and want to improve your skills and learn more about Korean music, art, literature, clothing, cuisine and traditions and much more.

We will cover different topics and develop our speaking skills.



# Tuesday

# Athletics



**“Don’t think about the start of the race, think about the ending!”**  
Use this quote from Usain Bolt to inspire you to get out there and run for your life.

**Athletics is a summer based sport with amazing opportunities in both track and field with events such as; 100m, 200m, 400m, 800m, 1500m, relay, javelin, shot put, discuss, long jump, triple jump and many others. There is an event for ALL.**

**Come and find your athletics talent and enjoy being out in the summer sunshine during enrichment.**

# Tuesday

# Board Games



"Think fast, play smart, and beat the best. Board Games Enrichment: It's your move."



# Tuesday

# CAD/CAM Club



7

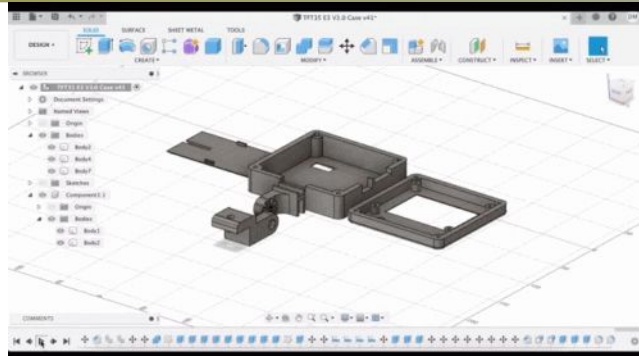

CAD/CAM (Computer-Aided Design and Computer-Aided Manufacturing) software streamlines production by integrating 3D modeling with automated machining, creating high-precision parts, prototypes, and tools.

If you are interested in using computer software to make exciting things then this is the design technology enrichment for you!

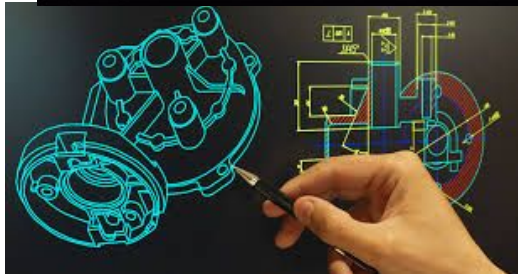

# Tuesday

# Cricket



**LBW . The crease. No ball. Wicket. Googly. Howzat!  
If any of these words mean anything to you...sign up  
for cricket!**

**Interested in playing cricket for the school in  
fixtures? Or do you want to learn more about the  
sport in general?**

**In this enrichment we look at developing the skills  
around cricket.**



# The Green Leaf Press

## Tuesday



7

8

9

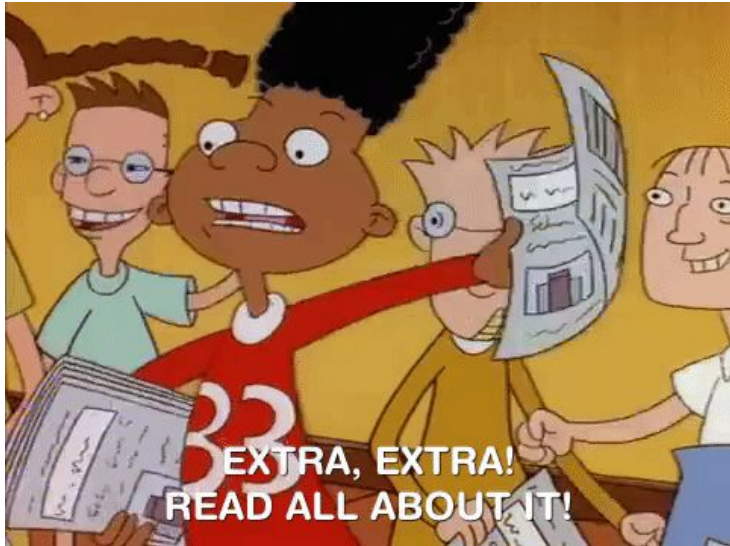

**Want to see your name in print?**

**Want to work as part of a creative team?**

**Want to make an impact and get messages across to the whole school?**

**Want to interview local figures?**

**Come and write for The Green Leaf Press! The new RTS school magazine.**

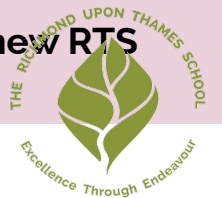

# Happy Minds

## Tuesday



7



Do you sometimes feel stressed or overwhelmed after a challenging day?

Looking to make new friends and try new activities in a peaceful and friendly environment?

During Happy Minds enrichment, take part in activities and discussions which aim to relax and de-stress - promoting mindfulness!



# Happy Minds

## Tuesday



89

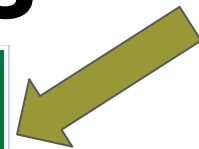

Do you sometimes feel stressed or overwhelmed after a challenging day?

Looking to make new friends and try new activities in a peaceful and friendly environment?

During Happy Minds enrichment, take part in activities and discussions which aim to relax and de-stress - promoting mindfulness!



# Tuesday



# Lego Robots



7 8

- Do you like Lego?
- Do you like coding?
- Do you want to attend a competition entering our robot against other schools?
- Do you want to work on projects that have a real-world engineering connection?

## Come join Lego Robots

Previous themes include:



This year's theme is:



# Mandarin Mavericks

## Tuesday



**Level up your skills with Mandarin!**

**Impress your friends, ace future opportunities and definitely stand out from the crowd with a new language**

**Mandarin is one of the most spoken languages in the world.**

**So become a Mandarin Maverick and unlock a new world of adventure!**



# Tuesday

# Pixar Film Club



7 8 9

new



Like watching, discussing and reviewing movies?

Enjoy watching animated films from one of the best film production company in the world



# Tuesday

# Photography Club



789



Ever wondered how to capture the best picture or how some of the best effects are created using just a lens. Step into the world of photography. Cameras, ipads or other devices- this club will help you understand how to take the perfect shot.

# Tuesday

# Rounders



7

8

9



Whether you are a bowler, a batter or an all-rounder, or just want to learn how to play.

Come and score some rounders and have some fun in the sun!



# The Reel Humanities

## Tuesday



7 8 9

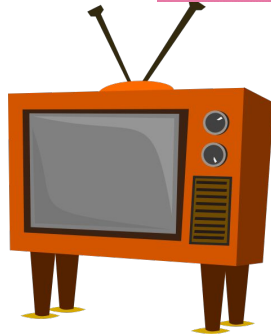
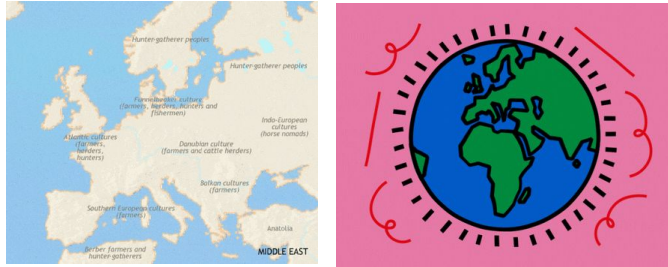

The Reel Humanities is a fun and thought-provoking club where we watch films and documentaries that bring history and geography to life.

Each week, we'll watch short clips or full-length features, followed by lively discussions, fun activities, or creative challenges related to the film or documentary we have watched.



# Preferences

*CHOOSE THREE ACTIVITIES*



# Thursday

# Athletics

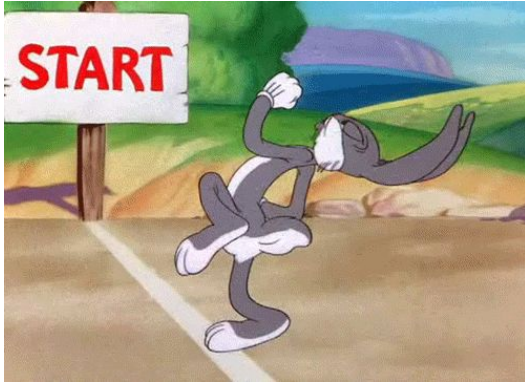

**“Don’t think about the start of the race, think about the ending!”**  
Use this quote from Usain Bolt to inspire you to get out there and run for your life.

**Athletics is a summer based sport with amazing opportunities in both track and field with events such as; 100m, 200m, 400m, 800m, 1500m, relay, javelin, shot put, discuss, long jump, triple jump and many others. There is an event for ALL.**

**Come and find your athletics talent and enjoy being out in the summer sunshine during enrichment.**

# Thursday

# CAD/CAM Club



8

new

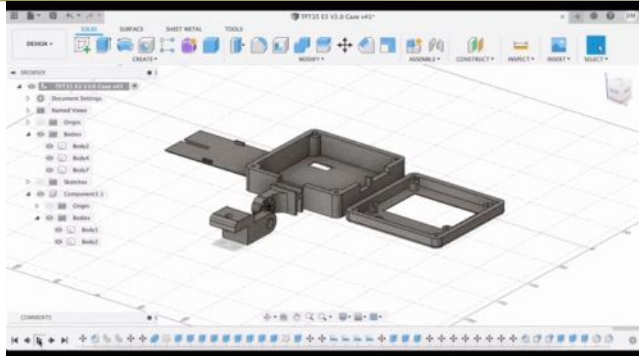

CAD/CAM (Computer-Aided Design and Computer-Aided Manufacturing) software streamlines production by integrating 3D modeling with automated machining, creating high-precision parts, prototypes, and tools.

If you are interested in using computer software to make exciting things then this is the design technology enrichment for you!

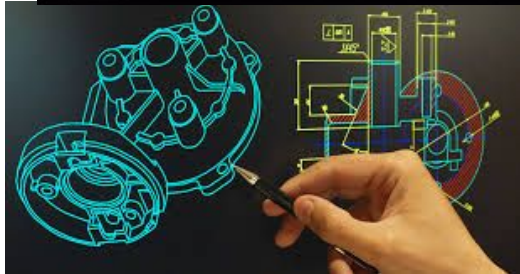

# Thursday

# Cricket



**LBW . The crease. No ball. Wicket. Googly. Howzat!**  
**If any of these words mean anything to you...sign up for cricket!**

**Interested in playing cricket for the school in fixtures? Or do you want to learn more about the sport in general?**

**In this enrichment we look at developing the skills around cricket.**



# Thursday

# Foreign Film Fanatics



7 8 9

Watching a film in a foreign language is a great way to improve your listening skills as well as pronunciation and we highly recommend trying this out !

French - Spanish - Italian - films, cartoons and songs with English subtitles!

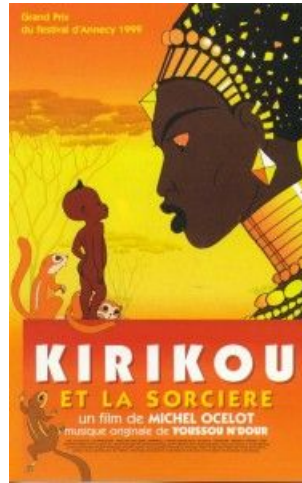

# Thursday

# Garden Gang



**Do you have greenfingers? Do you actually even know what that means?**

**This enrichment will give you the chance to get outdoors and nurture some nature.**

**A small group of you will find a space in the RTS grounds and plant some bulbs ready for a bodacious border of beauty...all grown by your very own hands**

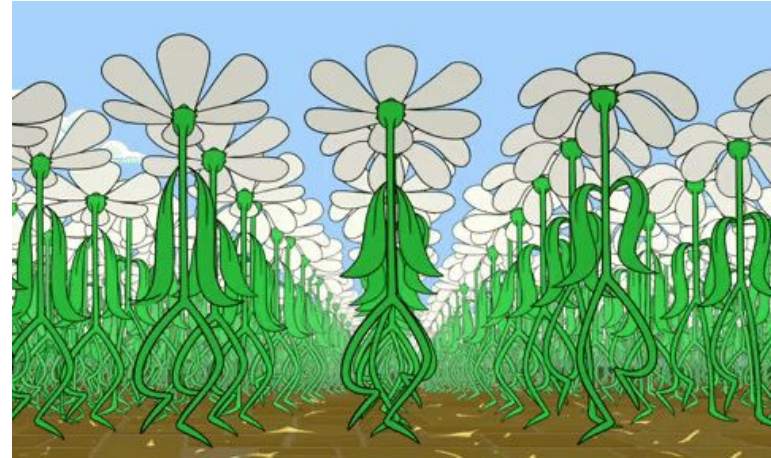

# Thursday

# Happy Minds



7 8 9

Do you sometimes feel stressed or overwhelmed after a challenging day?

Looking to make new friends and try new activities in a peaceful and friendly environment?

During Happy Minds enrichment, take part in activities and discussions which aim to relax and de-stress - promoting mindfulness!



# Thursday

# Marhaba!

new



7 8 9

Learn all about Arabic culture

Improve your skills and learn about Arabic music, art,  
literature, clothing, cuisine and traditions.

Learn Arabic phrases

We will cover different topics and develop our  
speaking skills.

Welcome to Arabic Club!



arabic alphabet

خ	ح	ج	ث	ت	ب	أ
kha'	h'aa'	jiim	thaa'	taa'	baa'	alif
ص	ش	س	ز	ر	ذ	د
saad	shiin	siin	zaay	raa'	thaa'	daal
ق	ف	غ	ع	ظ	ط	ض
qaaf	feh'	ghayn	'ayn	thaa'	Taa'	daad
و	و	ه	ن	م	ل	ك
yaa'	waaw	haa	nuun	miim	laam	kaaf

# Thursday

# Horse Care



8 9



Would you like to know how to look after horses and learn all about these beautiful, loyal, gentle animals then this is the enrichment for you!

You will learn what it's like to take care of horses

# Thursday

# Journalling Warriors

new



7 8 9



**Reflect! Create! Express!** Looking for a calm, creative space in your week?

Our Journalling Enrichment offers the chance to unwind, reflect, and explore their thoughts through writing. Whether you love being creative or just want a quiet moment to reset, this enrichment is a supportive place to express yourself.

**Explore journalling styles:** Gratitude logs, mood trackers, creative prompts, reflection pages, and goal-setting

**Get creative:** Use colours, layouts, and doodles to personalise your journal

Take time for yourself, discover your creativity, and build healthy habits that can last a lifetime. **Journalling Warriors** will give you a quiet corner for big ideas and personal growth



# Thursday

# Road Runners



Fed up of sitting around on a seat all day?  
Wish you could escape the four walls for an hour?  
Then, this is the Enrichment for you!

Road Runners will get out on the road to warm up and run in our local area.

You will need to make sure you have good trainers and ready for all weathers

Run RTS Run!

# Thursday

# Rounders



Whether you are a bowler, a batter or an all-rounder, or just want to learn how to play.

Come and score some rounders and have some fun in the sun!



# Thursday

# Photography Club



789



Ever wondered how to capture the best picture or how some of the best effects are created using just a lens. Step into the world of photography. Cameras, ipads or other devices- this club will help you understand how to take the perfect shot.



# Thursday

# Pixar Film Club



789



Like watching, discussing and reviewing movies?

Enjoy watching animated films from one of the best film production companies in the world



# RTS Battle of the Bands

## Thursday



789



Do you play an instrument and want to experience what it's like to be in a large ensemble?

Guitarists, pianists, singers, string players or just good listeners are welcome to join the big band and experience the thrill of live music.

Whether you are currently in a band, want to play solo, like a good Jam sesh or just enjoy listening to live music. Get involved!!



# Thursday

# Write On!



**The pen is mightier than the sword!**

**Where can you find inspiration to bring magic to your writing?**

**How can you bring your writing to life?**

**Who will you create in the land of make believe?**



